

# Lazy Boy Chair Raiser MF 1/3



## Multifit

Your Independence - Our Innovation

## Fitting Instructions

**PLEASE READ** - Before installation, if in doubt over the fixing of this Raiser, please contact Multifit directly.

**CHOOSE THE CORRECT RAISER** - As chair, sofa and bed designs are many and varied, it is important to choose a Raiser that best suits the type you have. Please refer to our website to see chair, sofa and bed types and the Raisers that fit them. We are also able to custom make raisers to suit, and fit them on site if required.



**USER PRECAUTIONS** - This product is only to be installed for the purpose for which it is intended (for furniture placed on a flat, stable and horizontal surface). If your raised furniture sits on a polished floor and you are concerned about it slipping around on the floor, then please order and fit our "non slip adhesive foot pads" to the bottom of the raiser. This raiser is for indoor use only.

**MAINTENANCE** - Check tightness of wing nuts / knobs and fixings periodically.

**CLEAN** - With damp cloth. Use non-abrasive detergent and dry thoroughly.

**MOVING** - Only move the raised furniture when it is unoccupied. After moving check that the raised furniture remains fitted correctly.

**ASSESSMENTS** - Clients who are very physical in the way they use their furniture can impose very high loads on the raised furniture. Part of the risk assessment should take this interaction into account when choosing the appropriate raiser.

**MAXIMUM USER WEIGHT** - 380 kg including the furniture. Please contact us for higher user weight limits.

**DEMONSTRATIONS** - Available on request. Phone 0800 102 803 (includes the Show your ability expo).



**PARTS REPLACEMENT** - Refer to [www.multifit.co.nz](http://www.multifit.co.nz) for a complete parts list.

**OPTIONAL EXTRAS** - Chair Side Transfer Rails. Non slip pads for the feet of the raiser. See [www.multifit.co.nz](http://www.multifit.co.nz)

**MISSION** - Our mission is to provide you with the safest, most cost effective raiser to meet your needs.

## Fitting this Raiser Safely



**WARNING Lifting Hazard** - We recommend the following method for fitting this type of raiser as it minimises the risk of back injury and ensures the raiser is fitted correctly. If in doubt, this method may require a second person to assist.

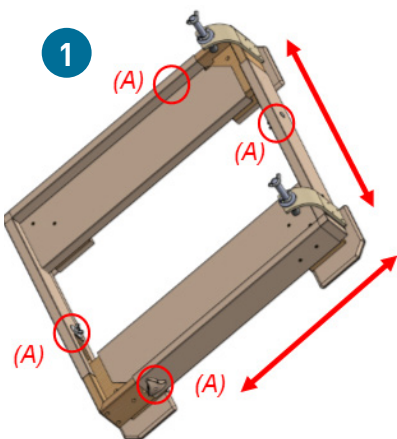

Loosen the four wing nuts (A) on the sides of the Raiser and expand it out to the approximate size of the base of the chair.

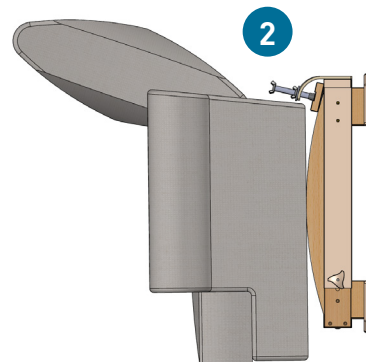

Roll the chair forward so the feet of the chair are accessible. Adjust the Raiser so the lip of the Raiser fits snugly over the base of the chair. Tighten the 4 x wing nuts firmly.

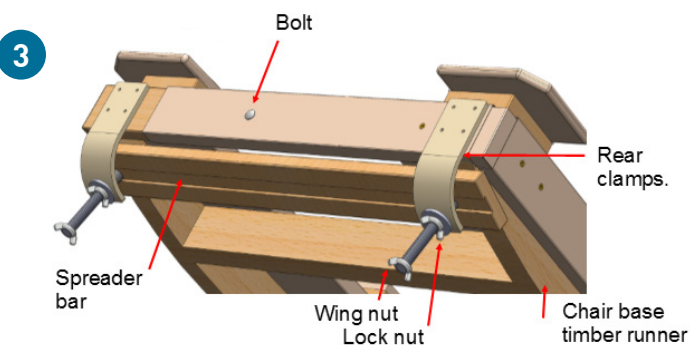

Clamp the raiser to the chair by placing the spreader bar over the timber runner of the chair base and tightening the rear clamps down onto the spreader bar. Tighten the lock nut.

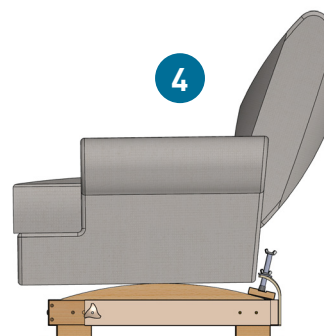

Carefully place chair upright. Check that all runners of the chair are positioned safely in the corners of the raiser. Sit on the raised chair and check that it feels safe. The raiser is now fitted and ready for use.

