



The ELK with Battery Airflo

UK Patent No. 2291040 – USA Patent No. 5669086

Instructions for use



The ELK is a four compartment emergency lifting cushion, which, when operated by a person experienced in its use, is designed to lift a person from the floor, to an elevated sitting position. Transfer to a chair or help to a standing position can then be offered. The ELK is powered by a Mangar Battery Airflo compressor and controlled using a Mangar 4-Way Hand Control. **These instructions are in 2 sections.** **Section 1** covers the operation of the ELK and **Section 2** covers the operation of the Battery powered Airflo compressor.

PLEASE BE SURE THAT YOU HAVE READ AND UNDERSTOOD BOTH SECTIONS OF THESE INSTRUCTIONS BEFORE OPERATING THIS EQUIPMENT.

WARNINGS:

1. **THIS EQUIPMENT MUST ONLY BE USED BY PERSONS EXPERIENCED IN ITS USE.**
2. **TO MAINTAIN STABILITY, PERSONS BEING LIFTED MUST HAVE THE ASSISTANCE OF ONE OR MORE COMPETENT ASSISTANTS.**
3. **USERS SHOULD ASSESS WHAT ASSISTANCE MAY BE REQUIRED BEFORE COMMENCING A LIFT.**
4. **ENSURE THAT THE SURFACE ON WHICH THE ELK IS TO BE PLACED, IS FREE FROM SHARP OBJECTS.**

Fig 1

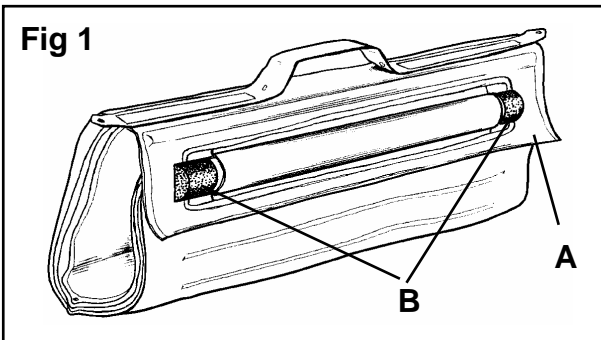

SECTION 1 (ELK)

STANDARD CONTENTS

1 x ELK; 1 x Battery powered Airflo Compressor (including battery charger); 1 x 4-Way Hand Control.

POSITIONING THE ELK

- Place the patient in the recovery position if they are unable to transfer themselves onto the ELK.

- Unroll the ELK by unclipping the flap (**A** fig.1) from the ends of the stability bar (**B** fig.1).
- Remove the end cap and then the stability bar from its pocket (**B** fig. 2) in order to provide a more comfortable transfer for the patient.
- Fold the edge of the ELK underneath itself, by folding along the line of the stability bar pocket (fig. 3).
- Position the ELK so that its 'upper' edge is approximately level with and tight up against the patient's waistband (fig. 4).

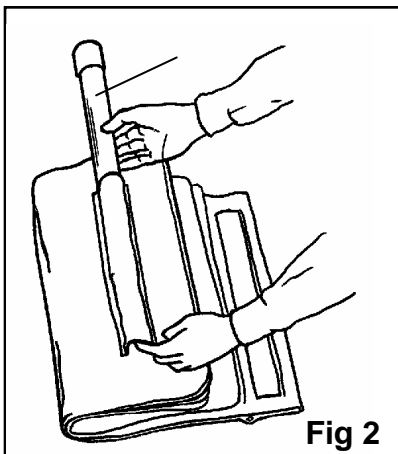

Fig 2



Fig 3

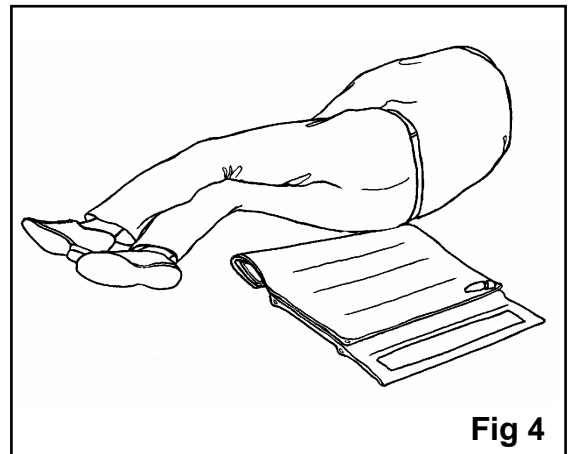
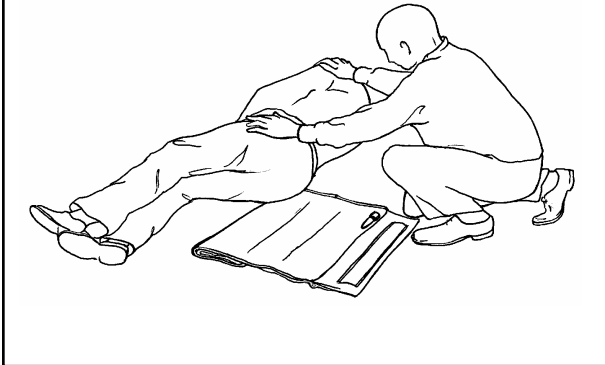

Fig 4

TRANSFERING THE PATIENT ONTO THE ELK

Fig 5



- Roll the patient over onto the ELK (Fig. 5)

Fig 6

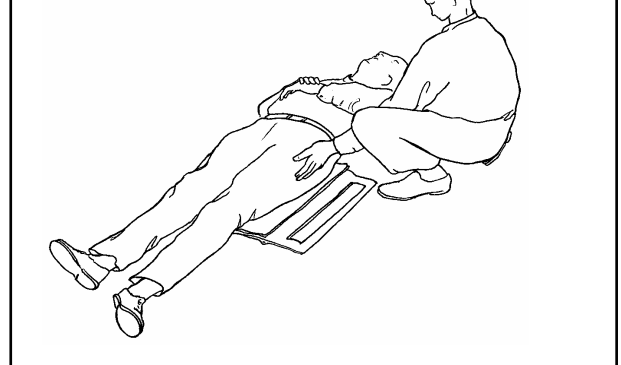

- Carry on rolling until the patient is lying fully and squarely on the ELK (Fig. 6)

Fig 7

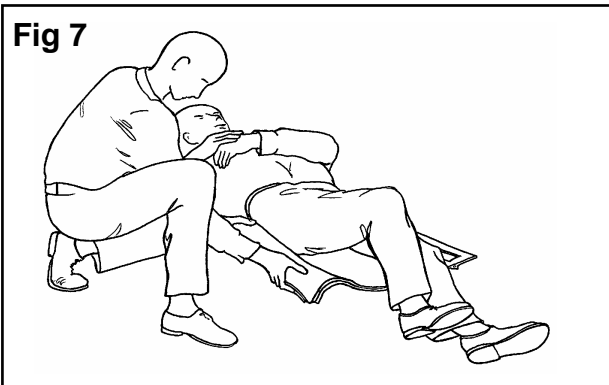

- Unfurl the folded over edge of the ELK (Fig. 7)

Fig 8

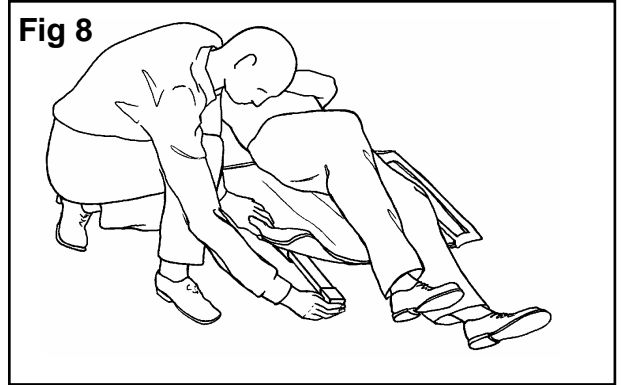

- Replace the stability bar and refit the end cap (Fig. 8)

CONNECTING THE 4-WAY HAND CONTROL AND AIRFLO

Fig 9

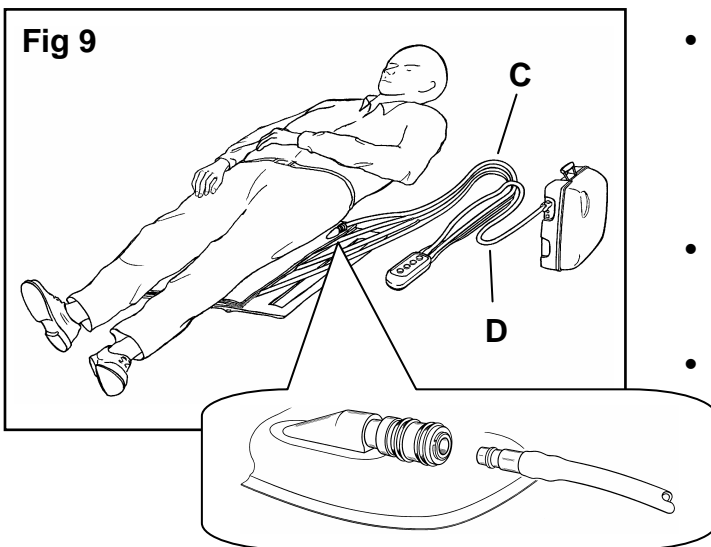

- Connect the four distribution hoses (**C** fig.9) from the 4-Way Hand Control to the four connectors on the ELK (Fig.9 inset). The ends of the hoses are color coded and numbered to match the corresponding ELK connectors (№ 4 is the top compartment; №1 the bottom).
- Position the Airflo compressor at the side of the ELK ensuring that it will not be in the way while lifting and supporting the patient.
- Connect the hose (**D** fig. 9) from the 4-Way Hand Control to the air outlet socket on the Airflo compressor and **SELECT THE 'AUTO' FUNCTION ON THE AIRFLO COMPRESSOR, TO ACTIVATE THE 'AUTO' FUNCTION, PRESS AND HOLD THE 'AUTO' BUTTON UNTIL ITS L.E.D. LIGHTS UP** (see Section 2 - Airflo instructions).



PLEASE BE SURE that you have read and fully understand the instructions relating to both the ELK and Airflo compressor before attempting to operate the equipment.



OPERATING INSTRUCTIONS

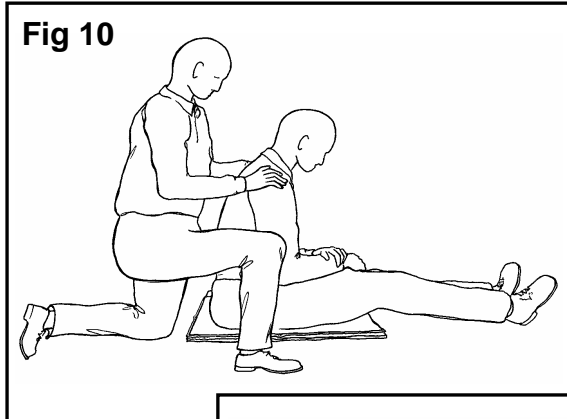

- Having positioned the ELK under the patient and connected it to the 4-Way Hand Control and Airflo compressor, position a sturdy chair, if possible, next to the patient, for them to hold to provide additional stability. When in the seated position, **the patient should place their arm on the chair seat to provide further stabilization.**
- Kneeling beside the patient, place them in a seated position on the ELK (Fig.10). If necessary, place a transfer belt (with looped handles) around the patient's chest and adjust to fit). Use the handles on this belt to provide additional support and stabilization while elevating.

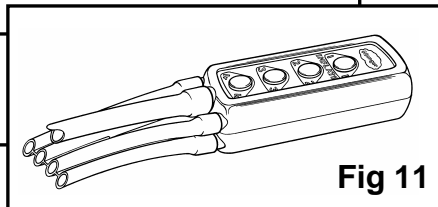

- Explain to the patient what to expect when the ELK elevates.
- Press the number 1 button on the 4-Way Hand Control (Fig.11). Steady the patient as the ELK lifts. Stop inflation when the first (bottom) compartment becomes hard. The compressor will automatically stop as each compartment becomes full.

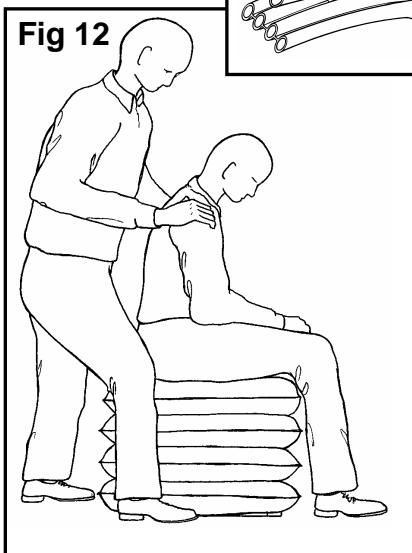

- Continue to operate buttons 2, 3 and 4, **in sequence**, in exactly the same manner. **Support the patient at all times. Always inflate the ELK sections from the BOTTOM UP BEGINNING WITH THE NO. 1 BUTTON.**
- When all four compartments are inflated, the patient may be helped to stand or to transfer (Fig. 12).
- To deflate, disconnect each of the air hoses from the ELK by pushing the release collar on the connector away from the hose and then pulling the hose clear of the connector.
- After use, roll the ELK up with the 4-Way Hand Control and re-secure the flap around the ends of the stability bar (see fig. 1).

WARNING: WHILE IN USE, NEVER ALLOW A CHAMBER TO BECOME PARTIALLY DEFLATED WHILE ANY CHAMBERS ABOVE IT ARE INFLATED. CHAMBERS MUST ALWAYS BE FULLY INFLATED FROM THE BOTTOM UP, IN SEQUENCE, IN ORDER TO MAINTAIN STABILITY.

ROUTINE CLEANING - Inflate the ELK, sponge clean with a detergent solution and dry thoroughly before storing in a dry place. **Do not dry using hot air.**

DISINFECTING- Inflate the ELK, sponge with a disinfecting solution or alcohol impregnated wipe. **Do not dry using hot air.**

SPECIFICATIONS (ELK) -

22½" Wide x 20" Deep x 22" High
 Maximum air pressure: 5psi
 Weight: 8lbs
 Maximum load: 1000lb

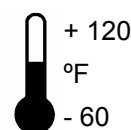

SECTION 2 (Airflo)

STANDARD CONTENTS

- 1 x Airflo compressor including two 12v-2.1Ah batteries (A)
- 1 x Battery charger (B)
- 1 x Mains charger cord (C)

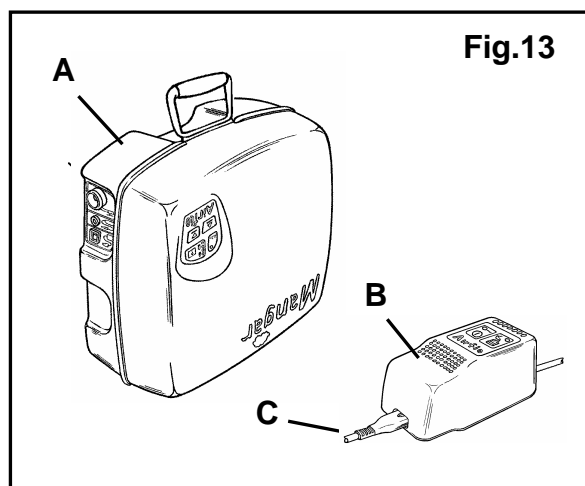

WARNINGS

- **DO NOT** place the battery charger in a damp environment.
- **ALWAYS** disconnect from the battery charger before cleaning.
- **USE ONLY** the supplied battery charger.
- **NOT SUITABLE** for use in the presence of flammable anesthetic mixtures with air, oxygen or nitrous oxide.

'AUTO' CONTROL BUTTON

To switch on, press and hold the  button for a few seconds until the LED (D fig.14) lights up.



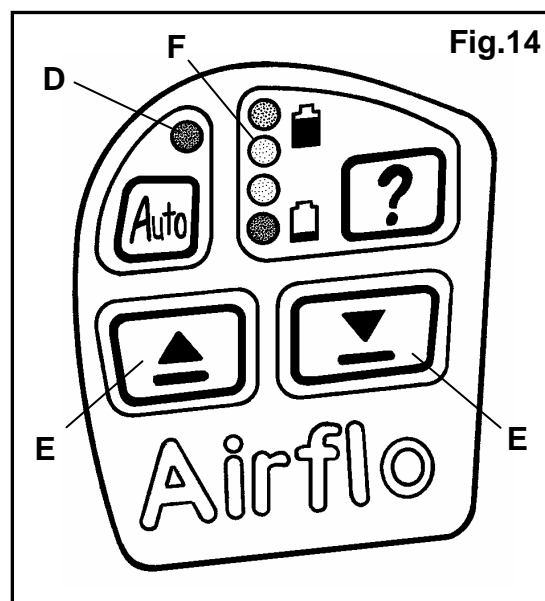

NOTE: When the Airflo is used with the 4-Way Hand Control, the in-built buttons (E fig.14) are **not** used; the 'Auto' function **must** be selected.

Pressing any of the in-built buttons will cancel the 'Auto' function. The 'Auto' function is designed for use with the 4-Way Hand Control and when selected, pressing the hand control buttons causes the Airflo to work automatically.



BATTERY GAUGE

Before use, check that the batteries are sufficiently charged. Ensure that the battery charger is disconnected from the Airflo and then press the  button to activate the indicator lights (F fig.14).

-  = (Green) fully charged
-  = (Yellow) partially discharged
-  = (Yellow) recharge soon
-  = (Red) recharge immediately (will not deflate)

The Airflo needs to be recharged when the lower of the two Yellow indicator lights is lit (see "Battery Charging" and "Battery Replacement").

BATTERY CHARGING

- Connect the battery charger DC output lead (**G** fig.15) to the Airflo charging socket (**H**) and the mains AC power supply lead (**J**) to a mains power supply socket. The 'power on' light (**K**) will glow. **NOTE:** The battery charger does not have an 'on/off' switch and therefore, the mains power supply lead (**J**) is the only mains power disconnect device.
- The charging light (**L**) will glow while the batteries are charging and go out when they are sufficiently charged. The light may flash when the batteries approach fully charged.

NOTE: Keep the Airflo on charge when not in use so as to maintain battery condition and to ensure that the Airflo is ready for use when needed. The batteries cannot be overcharged using this charger.

WARNING: DO NOT recharge the batteries in a damp environment.

CONNECTING THE AIR HOSE

- Connect the air hose from the Mangar 4-way Hand Control to the air outlet socket (**M** fig.16). The connector will 'click' into place when firmly pushed onto the outlet. To release the hose, press down the paddle on the connector.
- Select the 'Auto' function (see 'Auto' Control Button).

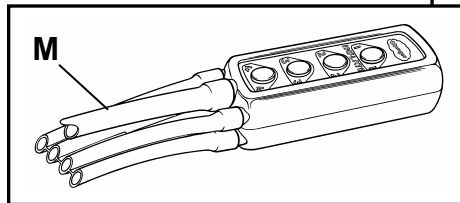

EXTRA AIR FLOW

The switch (**N** fig.17) on the underside of the Airflo changes the air flow from normal to high. **The switch should usually be set to 'Normal' and only changed to 'High' when directed to do so by the user instructions for the Mangar product that is to be inflated.** The high setting allows for faster inflation of the larger Mangar products such as the Mangar Wedge and Mangar Handy Bather.

- Press the switch to change between normal and high air flow.

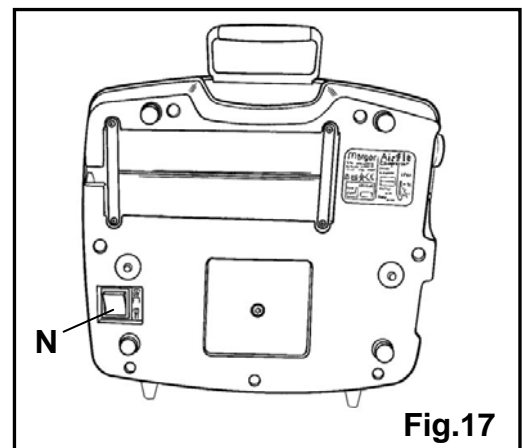
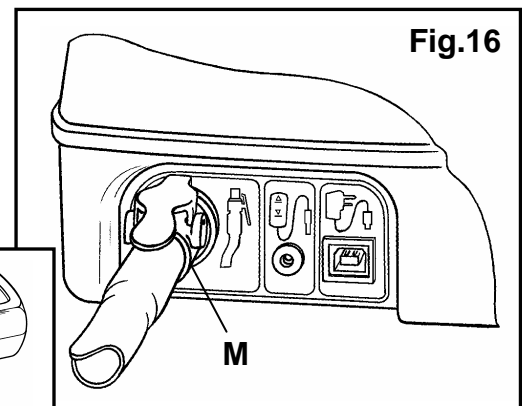
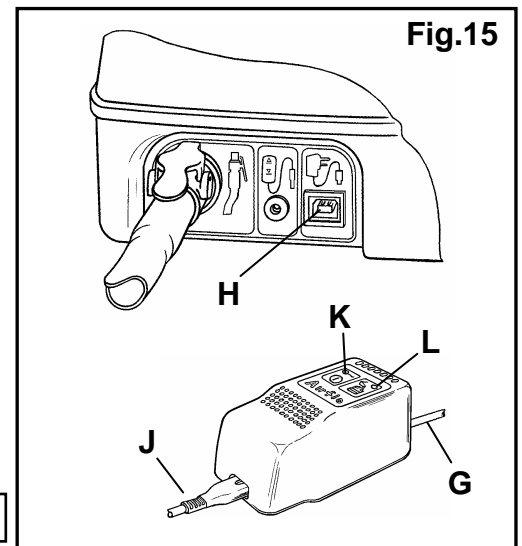
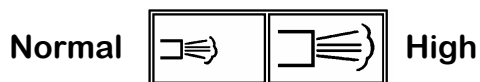

WARNING: DO NOT operate the normal/high air flow switch while the compressor is running.

CLEANING

- Ensure that the Airflo is unplugged from the battery charger. Clean the external surfaces using a damp cloth and allow to dry thoroughly before reconnecting to the battery charger. **Do not allow moisture to enter any part of the compressor.**
- Do not use solvent-based products.

STORAGE

- When not in use, store in a dry place. To maintain the batteries and to ensure that the Airflo is always ready for use, the Airflo should be left on charge.

MAINTENANCE

At approximately 12 month intervals, inspect and if necessary, clean the air filter located in the base of the Airflo (**P** fig.18). Wash the sponge element and thoroughly dry before replacing.

Battery replacement:

- Turn the Airflo upside down and remove the four screws (**Q** fig.18) using a № 1 posidrive screw driver, followed by the two battery supports and rubber spacers (**R** fig.18). Turn the Airflo the right way up to remove the batteries.
- Fit the replacement batteries so that their contacts are towards the centre line of the battery compartment.

IMPORTANT: Always replace both batteries and with the same type. Dispose of used batteries in accordance with local regulations.

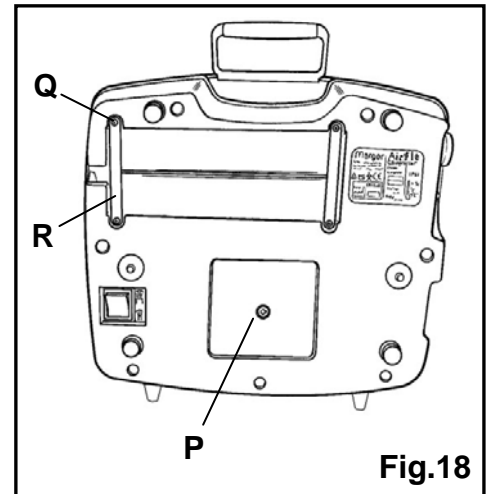

Fig.18

The Airflo contains no other serviceable parts. If a fault should develop (which may be indicated by repeated flashing lights on the battery gauge), please contact your supplier for further advice.

TROUBLE SHOOTING GUIDE

Compressor does not run when the 'up' button on the hand control is pressed.

Ensure that the 'Auto Function' has been selected.

The air hoses from the hand control to the ELK and Airflo must be connected before the compressor will work.

Compressor causes electrical interference with another piece of electrical equipment.

Move either the compressor or other item further away from each other until the interference stops.

Compressor keeps stopping when trying to inflate the ELK.

Check that there are no kinks in the air hoses.
 Check that the 'Normal/High' air flow switch is in the 'Normal' position.

'Auto' light flashing.

This happens when the compressor's internal temperature cut-out has tripped. Leave the Airflo switched off for 15 minutes to cool.

The top two lights on the Battery Gauge are flashing.

This happens when the overload cut-out has tripped. Press any button to reset.

SPECIFICATIONS

Airflo:

Weight: 13 lbs.

Output pressure: 5psi.

Batteries: 2 x 12v - 2.1Ah (Valve Regulated Sealed Lead Acid)

Environmental Protection: IP51

Type B Equipment

This equipment has been tested and meets the requirements of current EMC legislation.

Charger:

Input: 110v, 10VA

Output: 24v, 350mA

Charger Fuses:

Internal protection: 3A (T) Fuse

2A & 130°C Thermal Fuse

Environmental Protection: IP30

Double Insulated Class II Equipment



RECYCLE



DO NOT DISPOSE
OF IN TRASH

SYMBOLS USED ON AIRFLO AND CHARGER LABELS



ATTENTION CONSULT INSTRUCTIONS



TYPE B EQUIPMENT (PROTECTION AGAINST ELECTRIC SHOCK)



ALTERNATING CURRENT (AC)



FUSE (WITH RATING)

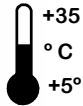

MAX/MIN OPERATING ENVIRONMENT TEMPERATURE



'AUTO' SELECT BUTTON



'UP' BUTTON (NOT USED WHEN 4-WAY HAND CONTROL IS CONNECTED)



'BATTERY CHARGING' INDICATOR



DO NOT CONNECT TO MAINS POWER IN A BATHROOM OR OUTDOORS



CLASS II DOUBLE INSULATED EQUIPMENT



DANGEROUS VOLTAGE



DIRECT CURRENT (DC)



DUTY CYCLE
I = Operating time
O = Non operating time



DATE OF MANUFACTURE



BATTERY GAUGE BUTTON



'DOWN' BUTTON (NOT USED WHEN 4-WAY HAND CONTROL IS CONNECTED)



'Mains power connected' INDICATOR

SYMBOLS USED ON PACKAGING



KEEP PACKAGING DRY



HANDLE WITH CARE

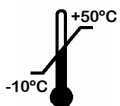

MAX/MIN STORAGE TEMPERATURE



STACK NO MORE THAN FIVE HIGH



NET & GROSS WEIGHTS

90% RH

MAX/MIN HUMIDITY WHEN TRANSPORTING IN PRESSURISED AIRCRAFT HOLD

10% RH

125 kPa

MAX/MIN PRESSURE WHEN TRANSPORTING IN PRESSURISED AIRCRAFT HOLD

73 kPa

+50°C

MAX/MIN TEMPERATURE WHEN TRANSPORTING IN PRESSURISED AIRCRAFT HOLD

-10°C



PLEASE RECYCLE PACKAGING